

DESCRIPTION

Solenoid valve 2 way normally closed
direct acting poppet type

CONSTRUCTION

| | |
|------------------|-----------------|
| Body | Stainless steel |
| Armature tube | Stainless steel |
| Plunger and core | Stainless steel |
| Springs | Stainless steel |
| Seal material | NBR |
| | FPM |
| | EPDM |



2

FEATURES

Maximum allowable pressure 50 bar *
Maximum fluid viscosity 25cSt (mm²/s)
Ambient temperature : with class F coil -10°C +55°C
with class H coil -10°C +80°C
Universal mounting position

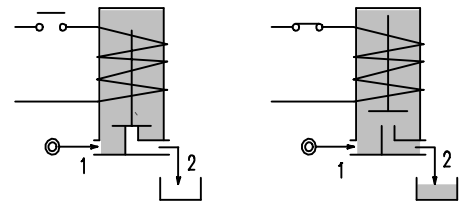
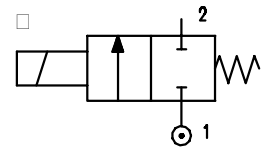

OPTIONS : Silver shading ring
Explosion proof coil according to ATEX - EExmII Series7
For use with oxygen

| CODE □ | Connection G ISO 228 | Orifice mm | KV m ³ /h | Differential pressure bar | | | Nominal power | | | Coil | | Seal □ | Temp. range °C |
|----------------------|----------------------------|---------------|-------------------------|------------------------------|-----|-----|---------------|---------------|------------|--------|-------|-----------|----------------------|
| | | | | Min | Max | | AC Inrush | VA Holding | DC Watt | Series | Width | | |
| | | | | | AC | DC | | | | | | | |
| E111A.....12///..... | 1/8" | 1.2 | 0.04 | 0 | 25 | 25 | 12 | 8 | 6.5 | 3 | 22 | NBR=B | -10 +90 |
| E111A.....15///..... | 1/8" | 1.5 | 0.06 | 0 | 16 | 16 | 12 | 8 | 6.5 | 3 | 22 | | |
| E111A.....20///..... | 1/8" | 2 | 0.09 | 0 | 12 | 10 | 12 | 8 | 6.5 | 3 | 22 | | |
| E111A.....25///..... | 1/8" | 2.5 | 0.14 | 0 | 8 | 5.5 | 12 | 8 | 6.5 | 3 | 22 | EPDM=E | <+140 |
| E111A.....31///..... | 1/8" | 3.1 | 0.19 | 0 | 5 | 2 | 12 | 8 | 6.5 | 3 | 22 | | |
| E111A.....20///..... | 1/8" | 2 | 0.09 | 0 | 25 | 15 | 15 | 11 | 5 | 4 | 30 | | |
| E111A.....25///..... | 1/8" | 2.5 | 0.14 | 0 | 16 | 8 | 15 | 11 | 5 | 4 | 30 | FPM=V | -10 +130 |
| E111A.....31///..... | 1/8" | 3.1 | 0.19 | 0 | 8 | 4 | 15 | 11 | 5 | 4 | 30 | | |

□ Seal Example: E111AB20///30B NBR seal
□ Coil Coil 24V 50/60Hz□

* REMARK: The maximum allowable pressure PS for steam is 2,5bar (gauge pressure)

BETA VALVE SYSTEMS LTD., PARK HOUSE BUSINESS CENTRE, DESBOROUGH PARK ROAD,
HIGH WYCOMBE, BUCKS. HP12 3DJ ENGLAND
T: +44(0)1494 459511 F: +44(0)1494 461136
E: sales@betavalve.com W: www.betavalve.com

| COILS | Alternating Current ~50/60Hz Volt | | | | | | | Direct Current Volt | | | Electrical connection | Connectors |
|------------------------------|--------------------------------------|-----|-----|-----|------------|-----|-----|------------------------|-----|-----|--------------------------|-------------------------|
| | 12 | 24 | 48 | 110 | 220 230 | 240 | 380 | 12 | 24 | 48 | | |
| Series 3 Width 22 Code | 30A | 30B | 30C | 30D | 30E | 30F | 30G | 300 | 301 | 302 | DIN 46244 | PG9 code 10348000 |
| Series 4 Width 30 Code | 40A | 40B | 40C | 40D | 40E | 40F | 40G | 400 | 401 | 402 | DIN 43650A | PG9 code 10349000 |

DESCRIPTION
 Class F insulation
 Voltage tolerance
 AC +15% -10%
 DC ± 10%
 Protection class
 IP65 with connector fitted
 IP00 without connector
 Continuous service ED100%

OPTIONS
 Class H insulation
 Cable attached
 Special coil voltages
 Special coil powers

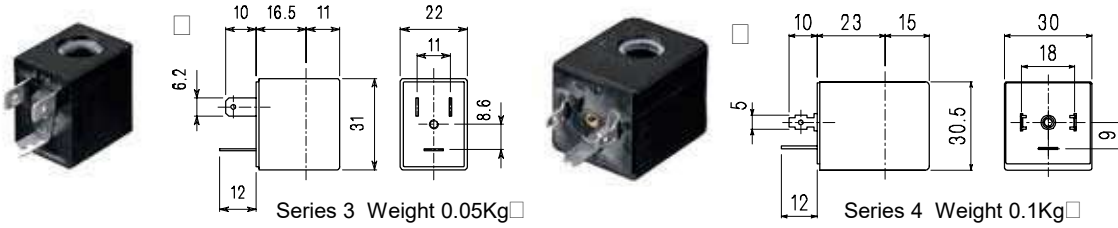

SPARE PARTS LIST

1. Coil fixing nut
2. Coil
3. Plunger
4. Armature tube with core

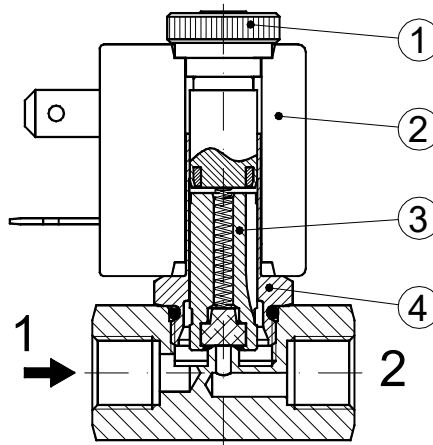

OVERALL DIMENSION

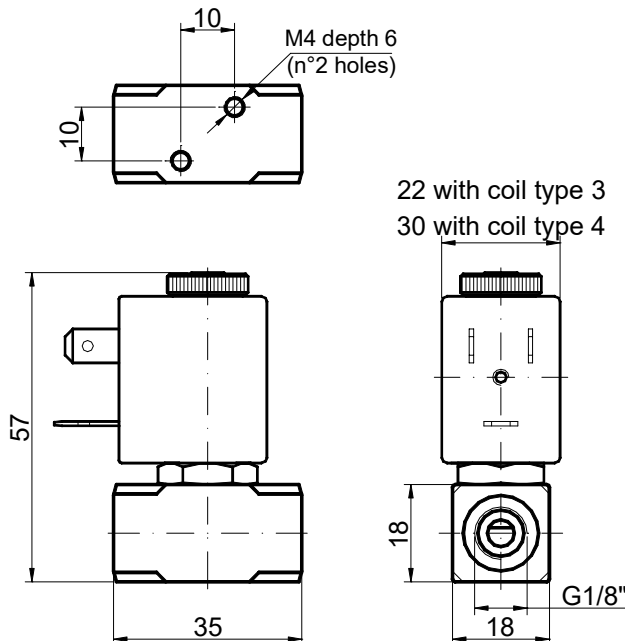

Weight with coil series 3 = 0.15 Kg
 Weight with coil series 4 = 0.20 Kg

